

Price List

PFC Capacitors and Key Components

with effect from 1st May 2015



The Company: EPCOS India Pvt. Ltd.

EPCOS India Private Limited (EIPL) is a Group company of TDK Corporation, Japan. EPCOS emerged in 1999 as a successor to the joint venture Siemens Matsushita Components and the former Siemens passive Components and Electron Tubes Group. The company has been selling electronic components in India since the early 60s. Today, all business activities in India come under the umbrella of EPCOS India Private Limited, having Registered head office at Kalyani Plant in West Bengal and regional offices in Mumbai, Delhi, Bengaluru and Kolkata. In mid-90s EPCOS significantly stepped up its commitment to India by opening new manufacturing facility at Kalyani in West Bengal and Nashik in Maharashtra. And now, EPCOS again reinforced its trust in India by opening up one more manufacturing facility at Bawal in Haryana.

EPCOS in India is involved in design, manufacturing and marketing of a broad range of top quality products such as AC-mfd capacitors, LV Power Factor Correction Capacitors (resin, inert gas and oil filled designs), Key Components required for PF

correction system, PF correction systems (APFC Panels), MV Capacitors, MV Capacitors Switch, MV Reactive Power Compensation systems, Power Electronic Capacitors, DC Capacitors, MPP film and high performance ferrite cores. Nashik factory also houses the Global R&D for Film metallisation, AC and PFC Products and Systems while Kalyani is Centre of Excellence for soft ferrites. EPCOS India also services the demands of customers for a wide variety of components from global factories of TDK.

EPCOS India has a strong sales and marketing team spread over the country. Our strength in market is based on the technical competence and marketing experience of our sales force. It is backed up by a very efficient and dedicated Channel Partner network to cover entire India and some neighbouring countries.

About TDK Corporation:

TDK is one of the leading electronic component manufacturers in the world.

Innumerable types of electronic components are the building blocks that sustain advanced applications in our modern world. TDK is a leading manufacturer of such components. Operating on a worldwide scale, TDK has R & D and manufacturing bases in Japan, the Asian region, Europe and America.

TDK Corporation was founded in 1935 in Japan to commercialize the world's first invented ferrite. The spirit of creating entirely new things of value by starting at the fundamental level of the material has defined TDK from the beginning, and it still is the trait that sets the company apart. With a forward-looking vision, TDK endeavors to protect the global environment and make innovation work for the betterment of mankind. The company is constantly striving to contribute to the industry and to society at large



Nashik Plant



Bawal Plant



Reactive Power Compensation or Power Factor Correction is the most simplest way of improving efficiency of the electrical energy and generating savings by energy conservation. Also with the emerging demand for power quality and growing awareness for the need of environmental protection, the complexity in the energy market is increasing; users and decision makers are

consequently finding it increasingly difficult to locate the best products and to make objective decisions.

EPCOS provides you a one stop shop solution for all your related needs.

From the house of EPCOS we can offer you a variety of Power Factor Correction Capacitors in

MPP, Gas filled and Oil filled technology. And also the important key components required for PF correction such as PF controllers, Capacitor Duty Contactors, Thyristor Switching Modules (TSM), Detuned Harmonic Filter Reactors etc.

Price List: Index

Product	Page no.
● SquareCap Capacitors	5
● PhiCap Capacitors	7
● PhiCap HD Capacitors	8
● PhaseCap Capacitors	9
● PhaseCap-SHD Capacitors	11
● LT-APP Capacitors	12
● AgriCap Capacitors	13
● Power Factor Controllers	15
● Capacitor Duty Contactors and TSM	17
● Detuned Filter Reactors	18

SquareCap Capacitor



Rectangular box type, self standing units. Modular construction with sheet metal enclosure.

Specification:

- Conformance to Standards IS 13340.

Range:

- Single units up to 50 KVAR.
- Voltage: 415V to 525V.

Available in three designs:

- ENDC: EPCOS Normal Duty Capacitor for normal inductive loads.
- EHDLL: EPCOS Heavy Duty Long Life Capacitor for loads exhibiting some amount of non-linearity, medium size industries.
- ESHDC: EPCOS Super Heavy Duty Capacitor for non-linear arduous and fluctuating loads.

Features:

- Manufactured using state-of-art metalisation process for MPP film with heavy edge.
- Self healing property.
- Low energy consumption.
- PU resin as impregnant.
- Safety device in the form of pressure sensitive (over pressure) mechanical interrupter.
- Simplified modular construction using hermetically sealed single phase basic capacitor cells.
- Easy and quick reparability at site.
- Temp class: -10/D.

PhiCap Capacitor



Stud mounting cylindrical type having very good KVAR to volume ratio.

Specification :

- Conformance to Standards IEC 60831-1 & 2 IS 13340

Range :

- Single unit up to 33.1 KVAR
- Voltage: 220V to 525V

Available in two designs :

- Normal duty for linear loads.
- Heavy duty for non-linear loads (up to 525V)

Features :

- Manufactured using state-of-art metalisation process for MPP film with heavy edge
- Self healing property
- Low energy consumption
- Soft biodegradable resin as impregnant
- Safety device in the form of pressure sensitive (over pressure) mechanical interrupter
- Temp class : -10/D.

PhaseCap Capacitor



A hi-tech capacitor with stud mounting Cylindrical construction with inert gas impregnated winding having very good inrush current capability and over current capability (up to 1.8 IR).

Specification :

- Conformance to Standards IEC 60831-1 & 2

Range :

- PhaseCap Energy Heavy Duty : Single units from 5 to 33 KVAR PhaseCap up to 56 KVAR
- Voltage : 230V to 690V (800/1000V on request)

Features :

- Manufactured using state-of-art wavecut technology for MPP film with heavy edge
- Self healing property
- Low energy consumption
- Capable of withstanding high inrush current up to **400.IR**
- **Dry-type**, freedom from oil leakage
- **Three phase safety device** in the form of pressure sensitive (over pressure) mechanical interrupter
- Compact size and light weight
- Temp class: -40/D

PoleCap Capacitor :

A modified version of PhaseCap capacitor with connection cable, suitable for long-term outdoor applications and for mounting on the pole.

Important Information: 1

Benefits of Power Factor Correction

- Fast return on investment through lower power costs.
 - Power factor correction reduces the reactive power in a system.
 - Power consumption and thus power costs drop in proportion.
- Effective use of installation
An improved power factor means that an electrical installation operates more economically (higher effective power for the same apparent power).
- Improved voltage quality.
- Reduced voltage drops.
- Optimum cable design.
 - Cable cross-sections can be reduced with improvement of power factor (less current).
In existing installations for instance, extra or higher power can be transmitted.
- Reduced transmission losses.
 - The transmission and switching devices carry less current, i.e. only the effective power, meaning that the ohmic losses in the leads are reduced.

SquareCap Capacitors

Rating KVAR	Description	Material Code	IR A	CN μF	H x W x D mm	Packing Units	MOQ	MRP/ Unit Rs.
SquareCap ENDC - 415 V(AC) 3PH, 50Hz (Series B32457)								
5	SQR ENDC 415V 50Hz-5KVAR 3PH	B32457L4005A 11	6.96	3 x 31	215 x 185 x 60	1	5	1474
10	SQR ENDC 415V 50Hz-10KVAR 3PH	B32457L4010A 11	13.91	3 x 62	300 x 240 x 80	1	5	2761
15	SQR ENDC 415V 50Hz-15KVAR 3PH	B32457L4015A 11	20.87	3 x 92.5	300 x 240 x 80	1	5	4142
25	SQR ENDC 415V 50Hz-25KVAR 3PH	B32457L4025A 11	34.78	6 x 77	300 x 240 x 160	1	2	6903
SquareCap ENDC - 440 V(AC) 3PH, 50Hz (Series B32457)								
1	SQR ENDC 440V 50Hz-1KVAR 3PH	B32457P5001A 11	1.31	3 x 5.5	95 x 125 x 45	1	40	314
2	SQR ENDC 440V 50Hz-2KVAR 3PH	B32457P5002A 11	2.62	3 x 11	120 x 125 x 45	1	40	561
3	SQR ENDC 440V 50Hz-3KVAR 3PH	B32457P5003A 11	3.94	3 x 16.5	120 x 145 x 55	1	40	842
4	SQR ENDC 440V 50Hz-4KVAR 3PH	B32457P5004A 11	5.25	3 x 22	140 x 145 x 55	1	20	1123
5	SQR ENDC 440V 50Hz-5KVAR 3PH	B32457L5005A 11	6.6	3 x 27.5	215 x 185 x 60	1	20	1403
6	SQR ENDC 440V 50Hz-6KVAR 3PH	B32457L5006A 11	7.9	3 x 33	300 x 240 x 80	1	5	1684
7	SQR ENDC 440V 50Hz-7KVAR 3PH	B32457L5007A 11	9.2	3 x 38.5	300 x 240 x 80	1	5	1965
7.5	SQR ENDC 440V 50Hz-7.5KVAR 3PH	B32457L5007A511	9.84	3 x 41.5	300 x 240 x 80	1	5	2105
8	SQR ENDC 440V 50Hz-8KVAR 3PH	B32457L5008A 11	10.5	3 x 44	300 x 240 x 80	1	5	2245
10	SQR ENDC 440V 50Hz-10KVAR 3PH	B32457L5010A 11	13.12	3 x 55	300 x 240 x 80	1	5	2630
12.5	SQR ENDC 440V 50Hz-12.5KVAR 3PH	B32457L5012A511	16.4	3 x 69	300 x 240 x 80	1	5	3287
15	SQR ENDC 440V 50Hz-15KVAR 3PH	B32457L5015A 11	19.68	3 x 82.5	300 x 240 x 80	1	5	3945
20	SQR ENDC 440V 50Hz-20KVAR 3PH	B32457L5020A 11	26.24	6 x 55	300 x 240 x 160	1	2	5260
25	SQR ENDC 440V 50Hz-25KVAR 3PH	B32457L5025A 11	32.8	6 x 69	300 x 240 x 160	1	2	6575
50	SQR ENDC 440V 50Hz-50KVAR 3PH	B32457L5050A 11	65.61	12 x 69	350 x 240 x 320	1	2	13150
SquareCap EHDLL - 415 V(AC) 3PH, 50Hz (Series B32459)								
5	SQR EHDLL 415V 50Hz-5KVAR 3PH	B32459L4005A 11	7.00	3 x 31	215 x 185 x 60	1	6	2146
10	SQR EHDLL 415V 50Hz-10KVAR 3PH	B32459L4010A 11	13.91	3 x 62	300 x 240 x 80	1	4	4014
15	SQR EHDLL 415V 50Hz-15KVAR 3PH	B32459L4015A 11	20.87	3 x 92	300 x 240 x 80	1	4	6022
25	SQR EHDLL 415V 50Hz-25KVAR 3PH	B32459L4025A 11	34.78	6 x 77	300 x 240 x 160	1	4	10036
50	SQR EHDLL 415V 50Hz-50KVAR 3PH	B32459L4050A 11	69.56	12 x 77	350 x 240 x 320	1	2	20072
SquareCap EHDLL - 440 V(AC) 3PH, 50Hz (Series B32459)								
1	SQR EHDLL 440V 50Hz-1KVAR 3PH	B32459L5001A 11	1.31	3 x 5.5	170 x 125 x 45	1	24	502
2	SQR EHDLL 440V 50Hz-2KVAR 3PH	B32459L5002A 11	2.62	3 x 11	170 x 125 x 45	1	24	1003
3	SQR EHDLL 440V 50Hz-3KVAR 3PH	B32459L5003A 11	3.94	3 x 16.5	215 x 185 x 60	1	20	1505
4	SQR EHDLL 440V 50Hz-4KVAR 3PH	B32459L5004A 11	5.25	3 x 22	215 x 185 x 60	1	20	2007
5	SQR EHDLL 440V 50Hz-5KVAR 3PH	B32459L5005A 11	6.56	3 x 27.5	215 x 185 x 60	1	10	2044
6	SQR EHDLL 440V 50Hz-6KVAR 3PH	B32459L5006A 11	7.9	3 x 33	300 x 240 x 80	1	4	2463
7.5	SQR EHDLL 440V 50Hz-7.5KVAR 3PH	B32459L5007A511	9.84	3 x 41.5	300 x 240 x 80	1	4	3066
8	SQR EHDLL 440V 50Hz-8KVAR 3PH	B32459L5008A 11	10.5	3 x 44	300 x 240 x 80	1	4	3271
10	SQR EHDLL 440V 50Hz-10KVAR 3PH	B32459L5010A 11	13.12	3 x 55	300 x 240 x 80	1	4	3823
12.5	SQR EHDLL 440V 50Hz-12.5KVAR 3PH	B32459L5012A511	16.4	3 x 69	300 x 240 x 80	1	4	4779
15	SQR EHDLL 440V 50Hz-15KVAR 3PH	B32459L5015A 11	19.68	3 x 82.5	300 x 240 x 80	1	4	5735
20	SQR EHDLL 440V 50Hz-20KVAR 3PH	B32459L5020A 11	26.24	6 x 55	300 x 240 x 160	1	4	7647
25	SQR EHDLL 440V 50Hz-25KVAR 3PH	B32459L5025A 11	32.8	6 x 69	300 x 240 x 160	1	4	9558
50	SQR EHDLL 440V 50Hz-50KVAR 3PH	B32459L5050A 11	65.61	12 x 69	350 x 240 x 320	1	2	19117
60	SQR EHDLL 440V 50Hz-60KVAR 3PH	B32459L5060A 11	78.7	12 x 82.2	350 x 240 x 320	1	2	22940
SquareCap EHDLL - 480 V(AC) 3PH, 50Hz (Series B32459)								
5	SQR EHDLL 480V 50Hz-5KVAR 3PH	B32459L8005A 61	6.01	3 x 23	215 x 185 x 60	1	20	2147
5.5	SQR EHDLL 480V 50Hz-5.5KVAR 3PH	B32459L8005A561	6.6	3 x 25.3	215 x 185 x 60	1	4	2361
10	SQR EHDLL 480V 50Hz-10KVAR 3PH	B32459L8010A 61	12.03	3 x 46.5	300 x 240 x 80	1	4	4014
11.1	SQR EHDLL 480V 50Hz-11.1KVAR 3PH	B32459L8011A161	13.4	3 x 51.1	300 x 240 x 80	1	4	4456
12.5	SQR EHDLL 480V 50Hz-12.5KVAR 3PH	B32459L8012A561	14.4	3 x 58	300 x 240 x 80	1	4	5018

SquareCap Capacitors

Rating KVAr	Description	Material Code	IR A	CN µF	H x W x D mm	Packing Units	MOQ	MRP/ Unit Rs.
SquareCap EHDLL - 480 V(AC) 3PH, 50Hz (Series B32459)								
13.8	SQR EHDLL 480V 50Hz-13.8KVAr 3PH	B32459L8013A861	16.6	3 x 63.6	300 x 240 x 80	1	4	5540
15	SQR EHDLL 480V 50Hz-15KVAr 3PH	B32459L8015A 61	18.04	3 x 69	300 x 240 x 80	1	4	6022
16.6	SQR EHDLL 480V 50Hz-16.6KVAr 3PH	B32459L8016A661	20	3 x 76.4	300 x 240 x 160	1	4	6664
20	SQR EHDLL 480V 50HZ-20KVAr 3PH	B32459L8020A 61	24.06	6 x 46.5	300 x 240 x 160	1	2	8029
22.1	SQR EHDLL 480V 50Hz-22.1KVAr 3PH	B32459L8022A161	26.6	6 x 51.1	300 x 240 x 160	1	2	8872
25	SQR EHDLL 480V 50Hz-25KVAr 3PH	B32459L8025A 61	30.07	6 x 58	300 x 240 x 160	1	2	10036
27.7	SQR EHDLL 480V 50Hz-27.7KVAr 3PH	B32459L8027A761	33.3	6 x 63.6	300 x 240 x 160	1	2	11120
50	SQR EHDLL 480V 50Hz-50KVAr 3PH	B32459L8029A 61	60.14	12 x 58	350 x 240 x 320	1	2	20072
SquareCap EHDLL - 525 V(AC) 3PH, 50Hz (Series B32459)								
6.6	SQR EHDLL 525V 50Hz-6.6KVAr 3PH	B32459L6006A 611	7.3	3 x 25.4	300 x 240 x 80	1	4	2833
9.9	SQR EHDLL 525V 50Hz-9.9KVAr 3PH	B32459L6009A 911	11	3 x 38.1	300 x 240 x 80	1	4	4250
13.2	SQR EHDLL 525V 50Hz-13.2KVAr 3PH	B32459L6013A 211	14.5	3 x 50.8	300 x 240 x 80	1	4	5299
16.6	SQR EHDLL 525V 50Hz-16.6KVAr 3PH	B32459L6016A 611	18.3	3 x 63.9	300 x 240 x 160	1	4	6664
26.5	SQR EHDLL 525V 50Hz-26.5KVAr 3PH	B32459L6026A 511	29.1	6 x 50.8	300 x 240 x 160	1	2	10638
33.1	SQR EHDLL 525V 50Hz-33.1KVAr 3PH	B32459L6033A 111	36.4	6 x 63.9	300 x 240 x 160	1	2	13288
SquareCap ESHDC - 415 V(AC) 3PH, 50Hz (Series B32455)								
5	SQR ESHDC 415V 50Hz-5KVAr 3PH	B32455L4005A 11	6.96	3 x 31	300 x 240 x 80	1	4	3434
10	SQR ESHDC 415V 50Hz-10KVAr 3PH	B32455L4010A 11	13.91	3 x 62	405 x 225 x 80	1	4	5987
15	SQR ESHDC 415V 50Hz-15KVAr 3PH	B32455L4015A 11	20.87	6 x 46.5	400 x 225 x 155	1	4	8980
25	SQR ESHDC 415V 50Hz-25KVAr 3PH	B32455L4025A 11	34.78	6 x 77	400 x 225 x 155	1	2	14967
50	SQR ESHDC 415V 50Hz-50KVAr 3PH	B32455L4050A 11	69.56	12 x 77	450 x 325 x 255	1	2	29934
SquareCap ESHDC - 440 V(AC) 3PH, 50Hz (Series B32455)								
1	SQR ESHDC 440V 50Hz-1KVAr 3PH	B32455L5001A 11	1.31	3 x 5.5	270 x 170 x 55	1	10	888
2	SQR ESHDC 440V 50Hz-2KVAr 3PH	B32455L5002A 11	2.62	3 x 11	270 x 170 x 55	1	10	1777
3	SQR ESHDC 440V 50Hz-3KVAr 3PH	B32455L5003A 11	3.94	3 x 16.5	300 x 240 x 80	1	10	2665
5	SQR ESHDC 440V 50Hz-5KVAr 3PH	B32455L5005A 11	6.56	3 x 27.5	300 x 240 x 80	1	4	3271
7.5	SQR ESHDC 440V 50Hz-7.5KVAr 3PH	B32455L5007A5 11	9.84	3 x 41.5	405 x 225 x 80	1	4	4906
10	SQR ESHDC 440V 50Hz-10KVAr 3PH	B32455L5010A 11	13.12	3 x 55	405 x 225 x 80	1	4	5702
12.5	SQR ESHDC 440V 50Hz-12.5KVAr 3PH	B32455L5012A5 11	16.4	3 x 69	405 x 225 x 80	1	4	7127
15	SQR ESHDC 440V 50Hz-15KVAr 3PH	B32455L5015A 11	19.68	6 x 41.5	405 x 225 x 155	1	4	8553
20	SQR ESHDC 440V 50Hz-20KVAr 3PH	B32455L5020A 11	26.24	6 x 55	400 x 225 x 155	1	2	11404
25	SQR ESHDC 440V 50Hz-25KVAr 3PH	B32455L5025A 11	32.8	6 x 69	400 x 225 x 155	1	2	14255
50	SQR ESHDC 440V 50Hz-50KVAr 3PH	B32455L5050A 11	65.61	12 x 69	450 x 325 x 225	1	2	28509
SquareCap ESHDC - 480 V(AC) 3PH, 50Hz (Series B32455)								
5	SQR ESHDC 480V 50Hz-5KVAr 3PH	B32455L8005A 11	6.01	3 x 23	300 x 240 x 80	1	10	3434
10	SQR ESHDC 480V 50Hz-10KVAr 3PH	B32455L8010A 11	12.03	3 x 46	405 x 225 x 80	1	4	5987
15	SQR ESHDC 480V 50Hz-15KVAr 3PH	B32455L8015A 11	18.04	6 x 34.5	400 x 225 x 155	1	4	8980
25	SQR ESHDC 480V 50Hz-25KVAr 3PH	B32455L8025A 11	30.07	6 x 58	400 x 225 x 155	1	2	14967
SquareCap ESHDC - 525 V(AC) 3PH, 50Hz (Series B32455)								
6.6	SQR ESHDC 525V 50Hz-6.6KVAr 3PH	B32455L6006A611	7.3	3 x 25.4	405 x 225 x 80	1	4	4533
10	SQR ESHDC 525V 50Hz-10KVAr 3PH	B32455L6010A 11	11	3 x 38.5	405 x 225 x 80	1	4	5987
13.2	SQR ESHDC 525V 50Hz-13.2KVAr 3PH	B32455L6013A211	14.5	3 x 50.8	405 x 225 x 80	1	4	7903
15	SQR ESHDC 525V 50Hz-15KVAr 3PH	B32455L6015A 11	16.5	6 x 28.9	400 x 225 x 155	1	4	8980
25	SQR ESHDC 525V 50Hz-25KVAr 3PH	B32455L6025A 11	27.49	6 x 48	400 x 225 x 155	1	2	14967
33.1	SQR ESHDC 525V 50Hz-33.1KVAr 3PH	B32455L6033A111	36.4	12 x 32	450 x 325 x 225	1	2	19817
50	SQR ESHDC 525V 50Hz-50KVAr 3PH	B32455L6050A 11	54.99	12 x 48	450 x 325 x 225	1	2	29934

PhiCap Capacitors

Rating KVAR	Description	Material Code	IR A	CN μF	D x H mm	Packing Units	MOQ	MRP/ Unit Rs.
PhiCap Normal Duty - 415 V(AC) 3PH, 50Hz (Series B32343 and B32344)								
5	PhiCap ROU 415V 50/60Hz-5/6KVAR 3PH	B32343L4052A 10	6.96	3 x 31	63.5 x 152	12	12	1160
10	PhiCap ROU 415V 50/60Hz-10/12KVAR 3PH	B32344B4102A 10	13.91	3 x 62	88.4 x 195	1	4	2321
12.5	PhiCap ROU 415V 50/60Hz-12.5/15KVAR 3PH	B32344B4122A510	17.39	3 x 77	88.4 x 270	1	4	2901
15	PhiCap ROU 415V 50/60Hz-15/18KVAR 3PH	B32344B4152A 10	20.87	3 x 92.5	88.4 x 270	1	4	3481
20	PhiCap ROU 415V 50/60Hz-20/24KVAR 3PH	B32344B4202A 10	27.82	3 x 123.5	88.4 x 345	1	4	4641
25	PhiCap ROU 415V 50/60Hz-25/30KVAR 3PH	B32344B4252A 10	34.78	3 x 154	88.4 x 345	1	4	5801
PhiCap Normal Duty - 440 V(AC) 3PH, 50Hz (Series B32343 and B32344)								
1	PhiCap ROU 440V 50/60Hz-1/1.2KVAR 3PH	B32343L4012A 40	1.31	3 x 5.5	53 x 117	12	12	274
2	PhiCap ROU 440V 50/60Hz-2.1/2.5KVAR 3PH	B32343L4021A540	2.8	3 x 11.5	53 x 117	12	12	548
3	PhiCap ROU 440V 50/60Hz-3/3.6KVAR 3PH	B32343L4032A 40	3.94	3 x 16.5	63.5 x 129	12	12	822
4	PhiCap ROU 440V 50/60Hz-4.2/5KVAR 3PH	B32343L4051A 40	5.51	3 x 23	63.5 x 129	12	12	1096
5	PhiCap ROU 440V 50/60Hz-5/6KVAR 3PH	B32343L4052A 40	6.56	3 x 27.5	63.5 x 152	12	12	1105
6	PhiCap ROU 440V 50/60Hz-6.0/7.2KVAR 3PH	B32344B4071A540	7.87	3 x 33	78.4 x 195	1	6	1326
7	PhiCap ROU 440V 50/60Hz-7/8.4KVAR 3PH	B32344B4072A 40	9.2	3 x 38.5	78.4 x 195	1	6	1547
7.5	PhiCap ROU 440V 50/60Hz-7.5/9KVAR 3PH	B32344B4072A540	9.84	3 x 41	78.4 x 195	1	6	1658
8.3	PhiCap ROU 440V 50/60Hz-8.3/10KVAR 3PH	B32344B4101A 40	10.89	3 x 45.5	78.4 x 195	1	6	1834
9	PhiCap ROU 440V 50/60Hz-9/10.8KVAR 3PH	B32344B4092A 40	11.8	3 x 49.5	78.4 x 195	1	6	1989
10	PhiCap ROU 440V 50/60Hz-10/12KVAR 3PH	B32344B4102A 40	13.12	3 x 55	88.4 x 195	1	4	2210
12.5	PhiCap ROU 440V 50/60Hz-12.5/15KVAR 3PH	B32344B4151A 40	16.4	3 x 68.5	88.4 x 270	1	4	2763
15	PhiCap ROU 440V 50/60Hz-15/18KVAR 3PH	B32344B4152A 40	19.68	3 x 82.5	88.4 x 270	1	4	3315
16.7	PhiCap ROU 440V 50/60Hz-16.7/20KVAR 3PH	B32344B4201A 40	21.9	3 x 91.5	88.4 x 345	1	4	3691
20	PhiCap ROU 440V 50/60Hz-20/24KVAR 3PH	B32344B4202A 40	26.24	3 x 110	88.4 x 345	1	4	4420
25	PhiCap ROU 440V 50/60Hz-25/30KVAR 3PH	B32344B4252A 40	32.8	3 x 137.5	93.5 x 345	1	4	5525
28	PhiCap ROU 440V 50/60Hz-28KVAR 3PH	B32344B4282A 40	36.7	3 x 153.5	93.5 x 345	1	4	6188
30	PhiCap ROU 440V 50/60Hz-30/36KVAR 3PH	B32344B4302A 40	39.4	3 x 164.5	93.5 x 345	1	4	6630
PhiCap Normal Duty - 480 V(AC) 3PH, 50Hz (Series B32344)								
5	PhiCap ROU 480V 50/60Hz-5/6KVAR 3PH	B32344B4052A 80	6.01	3 x 23	78.4 x 195	1	12	1160
5.5	PhiCapROU 480V 50/60Hz-5.5/6.6KVAR 3PH	B32343L4052A580	6.6	3 x 25.3	63.5 x 188	8	12	1276
8.3	PhiCap ROU 480V 50/60Hz-8.3/9.9KVAR 3PH	B32344B4082A380	10	3 x 28.2	78.4 x 270	1	6	1926
10.4	PhiCap ROU 480V 50/60Hz-10.4/12.5KVAR 3PH	B32344B4121A580	12.51	3 x 48	88.4 x 270	1	4	2413
11.1	PhiCap ROU 480V 50/60Hz-11.1/13.3KVAR 3PH	B32344B4112A180	13.4	3 x 51.1	78.4 x 270	1	4	2576
12.5	PhiCap ROU 480V 50/60Hz-12.5/15KVAR 3PH	B32344B4151A 80	15.04	3 x 58	88.4 x 345	1	4	2901
13.8	PhiCap ROU 480V 50/60Hz-13.8/13.3KVAR 3PH	B32344B4132A880	16.6	3 x 63.6	88.4 x 270	1	4	3202
15	PhiCap ROU 480V 50/60Hz-15/18KVAR 3PH	B32344B4152A 80	18.04	3 x 69	88.4 x 345	1	4	3481
16.6	PhiCap ROU 480V 50/60Hz-16.6/19.9KVAR 3PH	B32344B4162A680	20	3 x 76.5	88.4 x 345	1	4	3852
20.8	PhiCap ROU 480V 50/60Hz-20.8/25KVAR 3PH	B32344B4251A 80	25.02	3 x 96	88.4 x 345	1	4	4827
25	PhiCap ROU 480V 50/60Hz-25/30KVAR 3PH	B32344B4252A 80	30.07	3 x 115	93.5 x 345	1	4	5801
27.7	PhiCap ROU 480V 50/60Hz-27.7/33.2KVAR 3PH	B32344B4272A780	33.3	3 x 127.6	93.5 x 345	1	4	6428
30	PhiCap ROU 480V 50/60Hz-30/36KVAR 3PH	B32344B4302A 80	36.09	3 x 138	93.5 x 345	1	4	6962
PhiCap Normal Duty - 525 V(AC) 3PH, 50Hz (Series B32344)								
6.6	PhiCap ROU 525V 50/60Hz-6.6/7.9KVAR 3PH	B32343L5062A620	7.3	3 x 25.4	63.5 x 270	8	12	1532
8.3	PhiCap ROU 525V 50/60Hz-8.3/9.7KVAR 3PH	B32344B5082A320	9.13	3 x 32	88.4 x 270	1	6	1926
12.5	PhiCap ROU 525V 50/60Hz-12.5/15KVAR 3PH	B32344B5151A 20	13.75	3 x 48	88.4 x 270	1	4	2901
13.2	PhiCap ROU 525V 50/60Hz-13.2/15.8KVAR3PH	B32344B5132A220	14.5	3 x 50.8	88.4 x 270	1	4	3063
16.7	PhiCap ROU 525V 50/60Hz-16.7/20KVAR 3PH	B32344B5162A720	18.37	3 x 64	88.4 x 345	1	4	3875
20.8	PhiCap ROU 525V 50/60Hz-20.8/25KVAR 3PH	B32344B5202A820	22.87	3 x 80	93.5 x 345	1	4	4827
26.5	PhiCap ROU 525V 50/60Hz-26.5/31.8KVAR3PH	B32344B5262A520	29.5	3 x 102.1	121.5 x 325	1	2	6149
33.1	PhiCap ROU 525V 50/60Hz-33.1/39.7KVAR3PH	B32344B5332A120	36.4	3 x 127.5	121.5 x 325	1	2	7681

PhiCap HD Capacitors

Rating KVAR	Description	Material Code	IR A	CN μF	D x H mm	Packing Units	MOQ	MRP/ Unit Rs.
PhiCap Heavy Duty - 440 V(AC) 3Pz, 50Hz (Series B32447 and B32448)								
1	PhiCap HD ROU 440V 50/60Hz-1/1,2KVAR 3PH	B32447A4012B 40	1.3	3 x 5.5	53 x 117	12	12	420
2	PhiCap HD ROU 440V 50/60Hz-2/2,4KVAR 3PH	B32447A4022B 40	2.62	3 x 12.5	63.5 x 129	12	12	840
3	PhiCap HD SIG 440V 50/60Hz-3/3.6KVAR 3PH	B32448A4032B 40	3.94	3 x 16.5	78.4 x 195	1	6	1260
4	PhiCap HD SIG 440V 50/60Hz-4/4.8KVAR 3PH	B32448A4042B 40	5.25	3 x 22	78.4 x 195	1	6	1680
5	PhiCap HD SIG 440V 50/60Hz-5/6KVAR 3PH	B32448A4052B 40	6.56	3 x 27.5	78.4 x 195	1	6	1890
6	PhiCap HD SIG 440V 50/60Hz-6/7,2KVAR 3PH	B32448A4062B 40	7.8	3 x 33	88.4 x 195	1	6	2267
7.5	PhiCap HD SIG 440V 50/60Hz-7.5/9KVAR 3PH	B32448A4072B540	9.84	3 x 41.5	88.4 x 270	1	6	2834
8	PhiCap HD SIG 440V 50/60Hz-8/9,6KVAR 3PH	B32448A4082B 40	10.5	3 x 44	88.4 x 270	1	6	3023
10	PhiCap HD SIG 440V 50/60Hz-10/12KVAR 3PH	B32448A4102B 40	13.12	3 x 55	88.4 x 270	1	4	3779
12.5	PhiCap HD SIG 440V50/60Hz-12.5/15KVAR 3PH	B32448A4122B540	16.4	3 x 68.5	93.5 x 270	1	4	4724
15	PhiCap HD SIG 440V 50/60Hz-15/18KVAR 3PH	B32448A4152B 40	19.68	3 x 82.5	105.5 x 280	1	4	5669
20	PhiCap HD SIG 440V 50Hz-20KVAR 3PH	B32448A4202B840	26.24	3 x 109.6	121.5 x 280	1	4	7558
25	PhiCap HD SIG 440V 50Hz-25KVAR 3PH	B32448A4252B 40	32.8	3 x 137	121.5 x 325	1	4	9448
30	PhiCap HD SIG 440V 50Hz-30KVAR 3PH	B32448A4302B 40	39.4	3 x 164.5	142 x 325	1	4	11337
PhiCap Heavy Duty - 480 V(AC) 3PH, 50Hz (Series B32448)								
5	PhiCap HD SIG 480V 50/60Hz-5/6KVAR 3PH	B32448A4052B 80	6.01	3 x 23	78.4 x 195	1	6	1984
5.5	PhiCap HD SIG 480V 50/60Hz-5.5KVAR 3PH	B32448A4052A580	6.6	3 x 25.3	78.4 x 195	1	6	2182
8.3	PhiCap HD SIG 480V 50/60Hz-8.3KVAR 3PH	B32448A4082A380	10	3 x 38.2	88.4 x 270	1	6	3293
10	PhiCap HD SIG 480V 50/60Hz-10/12KVAR 3PH	B32448A4102B 80	12.03	3 x 46	88.4 x 270	1	4	3968
11.1	PhiCapHD SIG 480V 50/60Hz-11.1KVAR3PH	B32448A4112A180	13.4	3 x 51.1	88.4 x 270	1	4	4405
12.5	PhiCapHD SIG 480V 50/60HZ-12.5/15KVAR 3PH	B32448A4122B580	15.04	3 x 58	88.4 x 270	1	4	4960
16.6	PhiCap HD SIG480V 50/60Hz-16.6KVAR3PH	B32448A4162A680	20	3 x 76.5	88.4 x 345	1	4	6587
20	PhiCap HD SIG 480V 50Hz-20KVAR 3PH	B32448A4202B880	24.06	3 x 95.8	121.5 x 280	1	4	7936
22.1	PhiCap HD SIG 480V 50/60Hz-22.1KVAR 3PH	B32448A4222A180	26.6	3 x 101.8	105.5 x 280	1	2	8769
25	PhiCap HD SIG 480V 50HZ-25KVAR 3PH	B32448A4252B 80	30.07	3 x 115.1	121.5 x 325	1	4	9920
27.7	PhiCap HD SIG 480V 50Hz-27.7KVAR 3PH	B32448A4272A780	33.3	3 x 127.6	121.5 x 325	1	2	10992
30	PhiCap HD SIG 480V 50Hz-30KVAR 3PH	B32448A4302B 80	36.09	3 x 138.1	121.5 x 325	1	2	11904
PhiCap Heavy Duty - 525 V(AC) 3PH, 50Hz (Series B32448)								
5	PhiCap HD SIG 525V 50/60Hz-5/6kvar 3PH	B32448A5052B 20	5.5	3 x 19.3	78.4 x 195	1	1	1984
6.6	PhiCap HD SIG 525V 50/60Hz-6.6/7.9k 3PH	B32448A5062B620	7.3	3 x 25.4	88.4 x 195	1	1	2619
7.5	PhiCap HD SIG 525V 50/60Hz-7.5/9k 3PH	B32448A5072B520	8.2	3 x 28.9	88.4 x 195	1	1	2976
10	PhiCap HD SIG 525V 50/60Hz-10/12kvar 3PH	B32448A5102B 20	11	3 x 38.5	78.4 x 270	1	1	3968
12.5	PhiCap HD SIG 525V 50/60Hz-12.5/15k 3PH	B32448A5122B520	13.7	3 x 48.1	88.4 x 270	1	1	4960
13.2	PhiCap HDSIG 525V 50/60Hz-13.2/15.8k 3PH	B32448A5132B220	14.5	3 x 50.8	88.4 x 270	1	1	5238
15	PhiCap HD SIG 525V 50/60Hz-15/18kvar 3PH	B32448A5152B 20	16.5	3 x 57.8	93.5 x 270	1	1	5952
16.6	PhiCap HDSIG 525V 50/60Hz-16.6/19.9k 3PH	B32448A5162B620	18.3	3 x 63.9	105.5 x 280	1	1	6587
20	PhiCap HD SIG 525V 50/60Hz-20/24kvar 3PH	B32448A5202B 20	22	3 x 77	121.5 x 280	1	1	7936
25	PhiCap HD SIG 525V 50/60Hz-25/30kvar 3PH	B32448A5252B 20	27.5	3 x 96.3	121.5 x 325	1	1	9920
26.5	PhiCap HDSIG 525V 50/60Hz-26.5/31.8k 3PH	B32448A5262B520	29.1	3 x 102.1	121.5 x 325	1	1	10515
30	PhiCap HD SIG 525V 50/60Hz-30/36kvar 3PH	B32448A5302B 20	33	3 x 115.5	121.5 x 325	1	1	11904
33.1	PhiCap HDSIG 525V 50/60Hz-33.1/39.7k 3PH	B32448A5332B120	36.4	3 x 127.5	142 x 325	1	1	13134

PhaseCap Capacitors

Rating KVAR	Description	Material Code	IR A	CN μF	D x H mm	Packing Units	MOQ	MRP/ Unit Rs.
PhaseCap - 415 V(AC) 3PH, 50Hz (Series B25667 and B25669)								
5	PhaseCap 415V 50Hz 5KVAR 3PH	B25667L4926A375	6.96	3 x 30.8	121.6 x 164	1	4	2228
10	PhaseCap 415V 50Hz 10.4KVAR 3PH	B25667L4197A375	13.91	3 x 64.1	121.6 x 164	1	4	4455
12.5	PhaseCap 415V 50Hz 12.5KVAR 3PH	B25667L4237A375	17.39	3 x 77	121.6 x 164	1	4	5569
15	PhaseCap 415V 50Hz 15KVAR 3PH	B25667L4277A375	20.87	3 x 92.5	121.6 x 164	1	4	6683
20	PhaseCap 415V 50Hz 20.8KVAR 3PH	B25667L4387A375	27.82	3 x 128.2	121.6 x 200	1	4	8911
25	PhaseCap 415V 50Hz 25KVAR 3PH	B25667L4467A375	34.78	3 x 154.1	142 x 200	1	4	11138
50	PhaseCap HD 415V 50Hz 50KVAR 3PH	B25669L4927J375	69.56	3 x 308	142 x 350	1	2	22277
54	PhaseCap HD 415V 50Hz 54KVAR 3PH	B25669L4997J375	75.13	3 x 332	142 x 350	1	2	24059
PhaseCap - 440 V(AC) 3PH, 50Hz (Series B25667 and B25669)								
5	PhaseCap 440V 50Hz 5KVAR 3PH	B25667L4826A375	6.55	3 x 27.4	121.6 x 164	1	4	2122
7.5	PhaseCap 440V 50Hz 7.5KVAR 3PH	B25667L4127A375	9.84	3 x 41.1	121.6 x 164	1	4	3182
10.4	PhaseCap 440V 50Hz 10.4KVAR 3PH	B25667L4177A375	13.65	3 x 57	121.6 x 164	1	4	4413
12.5	PhaseCap 440V 50Hz 12.5KVAR 3PH	B25667L4207A375	16.4	3 x 68.5	121.6 x 164	1	4	5304
15	PhaseCap 440V 50Hz 15KVAR 3PH	B25667L4247A375	19.68	3 x 77.9	121.6 x 164	1	4	6365
20	PhaseCap 440V 50Hz 20KVAR 3PH	B25667L4347A375	26.24	3 x 114.1	142 x 200	1	4	8486
25	PhaseCap 440V 50Hz 25KVAR 3PH	B25667L4417A375	32.8	3 x 137.1	142 x 200	1	4	10608
35	PhaseCap HD 440V 50Hz 35KVAR 3PH	B25669L4577J375	45.93	3 x 192	142 x 317	1	2	14851
40	PhaseCap HD 440V 50Hz 40KVAR 3PH	B25669L4657J375	52.49	3 x 219	142 x 317	1	2	16973
50	PhaseCap HD 440V 50Hz 50KVAR 3PH	B25669L4827J375	65.61	3 x 274	142 x 355	1	2	21216
PhaseCap - 480 V(AC) 3PH, 50Hz (Series B25667)								
5	PhaseCap 480V 50Hz 5KVAR 3PH	B25667L4696A375	6.01	3 x 23	121.6 x 164	1	4	2228
6.25	PhaseCap 480V 50Hz 6.25KVAR 3PH	B25667L4866A375	7.52	3 x 28.3	121.6 x 164	1	4	2785
7.5	PhaseCap 480V 50Hz 7.5KVAR 3PH	B25667L4107A375	9.02	3 x 34.6	121.6 x 164	1	4	3342
10	PhaseCap 480V 50Hz 10.4KVAR 3PH	B25667L4147A375	12.03	3 x 47.9	121.6 x 164	1	4	4455
12.5	PhaseCap 480V 50Hz 12.5KVAR 3PH	B25667L4177A365	15.04	3 x 57.6	121.6 x 164	1	4	5569
15	PhaseCap 480V 50Hz 15KVAR 3PH	B25667L4207A365	18.04	3 x 69.1	121.6 x 200	1	4	6683
16.7	PhaseCap 480V 50Hz 16.7KVAR 3PH	B25667L4237A355	20.09	3 x 76.9	121.6 x 200	1	4	7440
20	PhaseCap 480V 50Hz 20.8KVAR 3PH	B25667L4287A375	24.06	3 x 95.8	142 x 200	1	4	8911
25	PhaseCap 480V 50Hz 25KVAR 3PH	B25667L4347A365	30.07	3 x 115.2	142 x 200	1	4	11138
28	PhaseCap 480V 50Hz 28KVAR 3PH	B25667L4387A365	34.00	3 x 129	142 x 200	1	4	12475
31	PhaseCap 480V 50Hz 31KVAR 3PH	B25667L4427A375	37.29	3 x 143	142 x 200	1	4	13812
PhaseCap - 525 V(AC) 3PH, 50Hz (Series B25667)								
6.25	PhaseCap 525V 50Hz 6.25KVAR 3PH	B25667L5726A375	7	3 x 24.1	121.6 x 164	1	4	2785
8	PhaseCap 525V 50Hz 8.33KVAR 3PH	B25667L5966A375	8.8	3 x 32.1	121.6 x 164	1	4	3564
10	PhaseCap 525V 50Hz 10.4KVAR 3PH	B25667L5127A375	11	3 x 40.1	121.6 x 164	1	4	4455
12.5	PhaseCap 525V 50Hz 12.5KVAR 3PH	B25667L5147A375	13.75	3 x 48.1	121.6 x 164	1	4	5569
15	PhaseCap 525V 50Hz 15KVAR 3PH	B25667L5177A375	16.5	3 x 57.1	121.6 x 200	1	4	6683
16.7	PhaseCap 525V 50Hz 16.7KVAR 3PH	B25667L5197A375	18.37	3 x 64.3	121.6 x 200	1	4	7440
20	PhaseCap 525V 50Hz 20.8KVAR 3PH	B25667L5247A375	21.99	3 x 80.1	142 x 200	1	4	8911
25	PhaseCap 525V 50Hz 25KVAR 3PH	B25667L5287A375	27.49	3 x 96.3	142 x 200	1	4	11138
30	PhaseCap 525V 50Hz 30KVAR 3PH	B25667L5347A375	32.99	3 x 115.5	142 x 200	1	4	13366



A hi-tech capacitor with stud mounting cylindrical construction having high inrush current capability (Up to 400.IR) and Over current capability (Up to 2.0 IR)

Specification:

- Conformance to standards IEC 60831-1+2, EN60831-1+2

Range:

- 5 to 33 KVAR
Voltage: 230V to 1000V

Features:

- Manufactured using state-of-art wave cut technology for MPP film with heavy edge.
- Self healing property
- Low energy consumption
- Capable of withstanding high inrush current (Up to 400.IR)
- Very High life expectancy
- Semi-dry biodegradable resin as impregnant
- Shock hazard protected terminals
- Safety device in the form of pressure sensitive (over pressure) mechanical interrupter
- Compact Size and Light weight.
- Temp class: -40°C to 60°C.



Low voltage APP power capacitors are non self-healing type capacitors designed and manufactured by using latest technology and high quality material. These capacitors employ a technique where in the dielectric comprises of both sides rough, hazy polypropylene film impregnated with a non PCB liquid. The fluid is biodegradable in environment. Electrodes are made of high purity, thin aluminum foils.

Specification:

- Conformance to Standard
- IS 13585

Range:

- Up to 50 KVAR, in single unit.
- Higher ratings in form of banks.
- Available in Ratings of 440, 480 and 525V. Voltages up to 1000V on request.

Features:

- Extended foil design.
- Low energy consumption. Leakproof CRCA sheet steel Container.
- Provided with internal element fuse.
- Extremely robust construction, suitable for use in arduous applications including applications related to Tuned and Detuned Harmonic Filters.
- Suitable for indoor application.
- Temp class: -5/D.

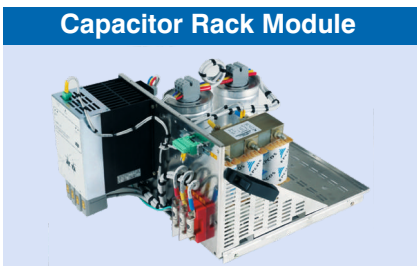

EPCOS offers State of the Art solutions - Rack Modules, (design registered) which are preassembled, using quality components from EPCOS. These are ready to use in APFC panel construction. This facilitates ease of fabrication and drastically reduces manufacturing lead time.

Technical Data :

- Standard Rating -12.5, 25 , 50 KVAR
- Voltage - 415V / 440V
- Capacitors - Phase Cap / Phi Cap
- Reactor - Aluminum / Copper wound
- Switching - Contactor / Thyristor
- Switchgear - Fuse / MCB / MCCB /SD
- Trolley dimensions (in mm)
410 (W) x 450 (D) x 310 (H)

Features :

- Compact with Optimal spacing between switchgear, Capacitor and reactor
- Appropriate selection of Capacitor and reactor rating
- Isolation Between switchgear and Capacitor -Reactor compartment
- Easy installation and accessibility with Draw-out type design
- Comfortable maintenance without any complexity
- Modularity in design offers, wide range of possible combinations
- Minimum inventory and logistic cost, makes this more suitable for bulk procurement
- Standardized rating of components
- Reliability in operation
- Low MTTR
- Type tested at ERDA..

Important Information: 2

Maximum Admissible Overvoltage			
Frequency (50 / 60 Hz)	Max. voltage (V _{rms})	Max. duration	Remarks
Line frequency	1.00 - V _R	Continuous duty	Highest mean during entire operating time of capacitor; exceptions (see below) are admissible for times of < 24 h
Line frequency	1.10 - V _R	8 h daily	Line voltage fluctuations
Line frequency	1.15 - V _R	30 min daily	Line voltage fluctuations
Line frequency	1.20 - V _R	5 min daily	Line voltage fluctuations
Line frequency	1.30 - V _R	1 min daily	Line voltage fluctuations
Line frequency with harmonics	Such that current does not exceed maximum admissible figure (I max. = 1.3 x I _R)		

PhaseCap-SHD Capacitors

Rating KVAR	Description	Material Code	IR A	CN μF	D x H mm	Packing Units	MOQ	MRP/ Unit Rs.
PhaseCap SHD - 415 V(AC) 3PH, 50Hz (Series B25673)								
5	PhaseCap SHD 415V 50Hz 5 KVAR 3PH	B25673L4052A 10	7	3 x 30.8	85 x 125	1	4	3144
6.2	PhaseCap SHD 415V 50Hz 6.2 KVAR 3PH	B25673L4062A 10	8.6	3 x 38.2	85 x 162	1	4	3899
7.5	PhaseCap SHD 415V 50Hz 7.5 KVAR 3PH	B25673L4072A510	10.4	3 x 46.2	85 x 162	1	4	4716
10.4	PhaseCap SHD 415V 50Hz 10.4 KVAR 3PH	B25673L4102A 10	14.5	3 x 64.1	100 x 162	1	4	5382
12.5	PhaseCap SHD 415V 50Hz 12.5 KVAR 3PH	B25673L4122A5101	7.4	3 x 77	100 x 200	1	4	6468
15	PhaseCap SHD 415V 50Hz 15 KVAR 3PH	B25673L4152A 10	20.9	3 x 92.5	100 x 200	1	4	7762
20.8	PhaseCap SHD 415V 50Hz 20.8 KVAR 3PH	B25673L4202A810	28.9	3 x 128.2	16 x 200	1	4	10763
25	PhaseCap SHD 415V 50Hz 25 KVAR 3PH	B25673L4252A 11	35	3 x 154	136 x 200	2	4	12937
PhaseCap SHD - 440 V(AC) 3PH, 50Hz (Series B25673)								
5	PhaseCap SHD 440V 50Hz 5 KVAR 3PH	B25673L4052A 40	6.6	3 x 27.4	85 x 125	1	4	2995
7.5	PhaseCap SHD 440V 50Hz 7.5 KVAR 3PH	B25673L4072A540	9.8	3 x 41.1	85 x 162	1	4	4492
10.4	PhaseCap SHD 440V 50Hz 10.4 KVAR 3PH	B25673L4102A 40	13.6	3 x 57	100 x 162	1	4	5125
12.5	PhaseCap SHD 440V 50Hz 12.5 KVAR 3PH	B25673L4122A540	16.4	3 x 68.5	100 x 162	1	4	6160
15	PhaseCap SHD 440V 50Hz 15 KVAR 3PH	B25673L4152A 40	19.7	3 x 82.2	100 x 200	1	4	7392
20	PhaseCap SHD 440V 50Hz 20 KVAR 3PH	B25673L4202A 40	26.3	3 x 109.7	116 x 200	1	4	9857
25	PhaseCap SHD 440V 50Hz 25 KVAR 3PH	B25673L4252A 40	32.8	3 x 137.1	116 x 200	1	4	12321
30	PhaseCap SHD 440V 50Hz 30 KVAR 3PH	B25673L4302A 41	39.2	3 x 164	136 x 200	1	4	14785
33	PhaseCap SHD 440V 50Hz 33 KVAR 3PH	B25673L4332A 41	43.3	3 x 181	136 x 200	1	4	16263
PhaseCap SHD - 480 V(AC) 3Pz, 50Hz (Series B25673)								
5.5	PhaseCap SHD 480V 50Hz 5.5 KVAR 3PH	B25673L4052A580	6.6	3 x 25.3	85 x 125	1	4	3459
6.3	PhaseCap SHD 480V 50Hz 6.3 KVAR 3PH	B25673L4062A380	7.6	3 x 29	85 x 162	1	4	3962
8.3	PhaseCap SHD 480V 50Hz 8.3 KVAR 3PH	B25673L4082A380	10	3 x 38.2	85 x 162	1	4	5220
11	PhaseCap SHD 480V 50Hz 11 KVAR 3PH	B25673L4112A 80	13.2	3 x 50.7	100 x 162	1	4	5692
13.8	PhaseCap SHD 480V 50Hz 13.8 KVAR 3PH	B25673L4132A880	16.6	3 x 63.6	100 x 200	1	4	7141
16.7	PhaseCap SHD 480V 50Hz 16.7 KVAR 3PH	B25673L4162A780	20.1	3 x 76.9	100 x 200	1	4	8642
22	PhaseCap SHD 480V 50Hz 22 KVAR 3PH	B25673L4222A 80	26.5	3 x 101.4	116 x 200	1	4	11384
28	PhaseCap SHD 480V 50Hz 28 KVAR 3PH	B25673L4282A 81	33.4	3 x 128	136 x 200	1	4	14489
PhaseCap SHD - 525 V(AC) 3PH, 50Hz (Series B25673)								
6.6	PhaseCap SHD 525V 50Hz 6.6 KVAR 3PH	B25673L5062A620	7.3	3 x 25.4	85 x 162	1	4	4150
10	PhaseCap SHD 525V 50Hz 10 KVAR 3PH	B25673L5102A 20	11	3 x 38.5	100 x 162	1	4	5175
13.2	PhaseCap SHD 525V 50Hz 13.2 KVAR 3PH	B25673L5132A220	14.5	3 x 50.8	100 x 200	1	4	6831
16.7	PhaseCap SHD 525V 50Hz 16.7 KVAR 3PH	B25673L5162A720	18.4	3 x 64.3	116 x 200	1	4	8642
20	PhaseCap SHD 525V 50Hz 20 KVAR 3PH	B25673L5202A 20	22	3 x 77	116 x 200	1	4	10349
26.5	PhaseCap SHD 525V 50Hz 26.5 KVAR 3PH	B25673L5262A521	29	3 x 102.1	136 x 200	1	4	13713
33.1	PhaseCap SHD 525V 50Hz 33.1 KVAR 3PH	B25673S5332L120	36	3 x 127.5	136 x 224	1	4	17128
37.1	PhaseCap SHD 525V 50Hz 37.1 KVAR 3PH	B25673S5372L120	41	3 x 142.9	136 x 224	1	4	19198

LT-APP Capacitors

Rating KVAR	Description	Material Code	IR A	CN μF	H x W x D mm	Packing Units	MOQ	MRP/ Unit Rs.
LT - APP - 440V(AC) 3PH, 50Hz (Series B25160)								
5	CAP UNIT 5KVAR,440V,50Hz, 3Ø Comp	B25160C4005T 40	6.56	41.1	135 x 75 x 330	1	1	3530
7.5	CAP UNIT 7.5KVAR,440V,50Hz, 3Ø Comp	B25160C4007T540	9.84	61.65	135 x 85 x 330	1	1	5080
10	CAP UNIT 10KVAR,440V,50Hz, 3Ø Comp	B25160C4010T 40	13.12	82.2	135 x 115 x 330	1	1	5778
12	CAP UNIT 12KVAR, 440V,50Hz, 3Ø Comp	B25160C4012T 40	16.4	102.75	155 x 115 x 330	1	1	7236
15	CAP UNIT 15KVAR,440V,50Hz, 3Ø Comp	B25160C4015T 40	19.68	123.3	175 x 115 x 330	1	1	8680
20	CAP UNIT 20KVAR,440V,50Hz, 3Ø Comp	B25160C4020T 40	26.24	164.39	225 x 115 x 355	1	1	10680
25	CAP UNIT 25KVAR,440V,50Hz, 3Ø Comp	B25160C4025T 40	32.8	205.49	195 x 115 x 455	1	1	13360
30	CAP UNIT 30KVAR,440V,50Hz, 3Ø Comp	B25160C4030T 40	39.37	246.59	225 x 115 x 455	1	1	15360
40	CAP UNIT 40KVAR,440V,50Hz, 3Ø Comp	B25160C4040T 40	52.49	329	275 x 115 x 455	1	1	20700
50	CAP UNIT 50KVAR,440V,50Hz, 3Ø Comp	B25160C4050T 40	65.61	410.99	335 x 115 x 455	1	1	22878
LT - APP - 480 V(AC) 3PH, 50Hz (Series B25160)								
5.5	CAP UNIT 5.5KVAR,480V,50Hz, 3Ø Comp	B25160C4005T580	6.62	37.99	135 x 75 x 330	1	1	4266
8.3	CAP UNIT 8.3KVAR,480V,50Hz, 3Ø Comp	B25160C4008T380	9.98	57.33	135 x 85 x 330	1	1	5620
10	CAP UNIT 10KVAR,480V,50Hz, 3Ø Comp	B25160C4010T 80	12.03	69.07	135 x 100 x 330	1	1	6102
11.1	CAP UNIT 11.1KVAR,480V,50Hz, 3Ø Comp	B25160C4011T180	13.35	76.67	135 x 115 x 330	1	1	6732
12.5	CAP UNIT 12.5KVAR,480V,50Hz, 3Ø Comp	B25160C4012T580	15.04	86.34	135 x 115 x 330	1	1	7650
13.8	CAP UNIT 13.8KVAR,480V,50Hz, 3Ø Comp	B25160C4013T880	16.6	95.31	155 x 115 x 330	1	1	7916
15	CAP UNIT 15KVAR,480V,50Hz, 3Ø Comp	B25160C4015T 80	18.04	103.6	155 x 115 x 330	1	1	9162
16.6	CAP UNIT 16.6KVAR,480V,50Hz, 3Ø Comp	B25160C4016T680	19.97	114.65	175 x 115 x 330	1	1	9864
20	CAP UNIT 20KVAR,480V,50Hz, 3Ø Comp	B25160C4020T 80	24.06	138.14	195 x 115 x 355	1	1	11124
22.1	CAP UNIT 22.1KVAR,480V,50Hz, 3Ø Comp	B25160C4022T180	26.58	152.64	210 x 115 x 355	1	1	12294
25	CAP UNIT 25KVAR,480V,50Hz, 3Ø Comp	B25160C4025T 80	30.07	172.67	225 x 115 x 355	1	1	13896
27.7	CAP UNIT 27.7KVAR,480V,50Hz, 3Ø Comp	B25160C4027T780	33.28	191.11	185 x 115 x 455	1	1	15102
30	CAP UNIT 30KVAR,480V,50Hz, 3Ø Comp	B25160C4030T 80	36.09	207.21	195 x 115 x 455	1	1	16020
33.2	CAP UNIT 33.2KVAR,480V,50Hz, 3Ø Comp	B25160C4033T280	39.93	229.31	210 x 115 x 455	1	1	17594
40	CAP UNIT 40KVAR,480V,50Hz, 3Ø Comp	B25160C4040T 80	48.11	276.27	245 x 115 x 455	1	1	20366
44.3	CAP UNIT 44.3KVAR,480V,50Hz, 3Ø Comp	B25160C4044T380	53.29	305.97	275 x 115 x 455	1	1	21991
50	CAP UNIT 50kVAR,480V,50Hz, 3Ø Comp	B25160C4050T 80	60.14	345.34	295 x 115 x 455	1	1	23958
55.3	CAP UNIT 55.3KVAR,480V,50Hz, 3Ø Comp	B25160C4055T380	66.52	381.95	315 x 115 x 455	1	1	26334
LT - APP - 525 V(AC) 3PH, 50Hz (Series B25160)								
5	CAP UNIT 5KVAR,525V,50Hz, 3Ø Comp	B25160C5005T 25	5.5	28.87	135 x 115 x 230	1	1	4266
6.6	CAP UNIT 6.6KVAR,525V,50Hz, 3Ø Comp	B25160C5006T625	7.26	38.11	155 x 115 x 230	1	1	5205
7.5	CAP UNIT 7.5KVAR,525V,50Hz, 3Ø Comp	B25160C5007T525	8.25	43.3	185 x 115 x 230	1	1	5940
8.3	CAP UNIT 8.3KVAR,525V,50Hz, 3Ø Comp	B25160C5008T325	9.13	47.92	185 x 115 x 230	1	1	6130
10	CAP UNIT 10KVAR,525V,50Hz, 3Ø Comp	B25160C5010T 25	11	57.74	210 x 115 x 230	1	1	6300
12.5	CAP UNIT 12.5KVAR,525V,50Hz, 3Ø Comp	B25160C5012T525	13.75	72.17	135 x 115 x 330	1	1	7650
13.2	CAP UNIT 13.2KVAR,525V,50Hz, 3Ø Comp	B25160C5013T225	14.52	76.21	135 x 115 x 330	1	1	7920
15	CAP UNIT 15KVAR,525V,50Hz, 3Ø Comp	B25160C5015T 25	16.5	86.6	155 x 115 x 330	1	1	9162
16.6	CAP UNIT 16.6KVAR,525V,50Hz, 3Ø Comp	B25160C5016T625	18.26	95.84	175 x 115 x 330	1	1	10037
20	CAP UNIT 20KVAR,525V,50Hz, 3Ø Comp	B25160C5020T 25	21.99	115.47	195 x 115 x 355	1	1	11124
25	CAP UNIT 25KVAR,525V,50Hz, 3Ø Comp	B25160C5025T 25	27.49	144.34	225 x 115 x 355	1	1	13896
26.5	CAP UNIT 26.5KVAR,525V,50Hz, 3Ø Comp	B25160C5026T525	29.14	153	245 x 115 x 355	1	1	14846
30	CAP UNIT 30KVAR,525V,50Hz, 3Ø Comp	B25160C5030T 25	32.99	173.21	195 x 115 x 455	1	1	16020
33.1	CAP UNIT 33.1KVAR, 525V,50Hz, 3Ø Comp	B25160C5033T125	36.4	191.11	210 x 115 x 455	1	1	17604
40	CAP UNIT 40KVAR,525V,50Hz, 3Ø Comp	B25160C5040T 25	43.99	230.94	245 x 115 x 455	1	1	19974
50	CAP UNIT 50kVAR,525V,50Hz, 3Ø Comp	B25160C5050T 25	54.99	288.68	295 x 115 x 455	1	1	23958
53	CAP UNIT 53kVAR,525V,50Hz, 3Ø Comp	B25160C5053T 25	58.29	306	295 x 115 x 455	1	1	24375
66.2	CAP UNIT 66.2kVAR,525V,50Hz, 3Ø Comp	B25160C5066T225	72.9	382.21	360 x 115 x 455	1	1	29258

AgriCap Capacitors

Rating KVAR	Description	Material Code	IR A	CN μF	D x H mm	Packing Units	MOQ	MRP/ Unit Rs.
Agri - Round - 440 V(AC) 3PH, 50HZ (Series B32454)								
1	AgriCap 440V 50HZ-1KVAR 3PH	B32454C5001T 10	1.31	3 x 5.5	40 x 137	25	25	153
2	AgriCap 440V 50HZ-2KVAR 3PH	B32454C5002T 10	2.62	3 x 11.0	50 x 132	25	25	305
3	AgriCap 440V 50HZ-3KVAR 3PH	B32454C5003T 10	3.94	3 x 16.5	53 x 132	25	25	458
4	AgriCap 440V 50HZ-4KVAR 3PH	B32454C5004T 10	5.25	3 x 22.0	63.5 x 132	20	20	611
5	AgriCap 440V 50HZ-5KVAR 3PH	B32454C5005T 10	6.56	3 x 27.5	63.5 x 132	20	20	763
6	AgriCap 440V 50HZ-6KVAR 3PH	B32454C5006T 10	7.87	3 x 33.0	63.5 x 157	20	20	916
7	AgriCap 440V 50Hz-7KVAR 3PH	B32454B5007T 10	9.19	3 X 38.4	68 x 159	16	16	1069
8	AgriCap 440V 50HZ-8KVAR 3PH	B32454B5008T 10	10.5	3 x 44.0	68 x 159	16	16	1221
10	AgriCap 440V 50Hz-10kvar 3PH	B32454C5010T 10	13.1	3 x 55	68 X 203	16	16	1526

Important Information: 3

Temperature Class of Capacitors (according IEC 60831-1)			
Temperature Class	Temperature of Air Surrounding the Capacitor		
	Maximum	Maximum mean for 24 h	Maximum mean for 1 year
B	45°C	35°C	25°C
C	50°C	40°C	30°C
D	55°C	45°C	35°C

Capacitors are divided into temperature classes. Each class is represented by a number followed by a letter, e.g. -40/D. The number is the lowest ambient temperature at which a capacitor may operate. The upper limit temperature is indicated by the letter (see table above).

The useful life of a capacitor depends very much on temperature. Proper cooling of a capacitor must ensure that the maximum temperature is not exceeded, otherwise useful life is degraded. When configuring a circuit, one should make sure that capacitors are not subjected to heat from adjacent

components (reactors, bus bars, etc.). Forced cooling is preferable for compact designs. And it is highly inadvisable to arrange capacitors directly above reactors. Exceeding specified temperature limits, may set in worst case the safety device out of operation.



BR 4000ET/ER



BR 4000ET

Technical Data :

- Steps - 4 , 6 and 8 relay outputs
- Current Input - 1A or 5 A
- Supply Voltage - 144VAC-288VAC
- Measurement Voltage : 144...288VAC (L-N)
- Operating temperature : 0 to 55 ° C
- Compact 96 x 96 x 75 mm
- Adapter plate for 144 x 144 cut out can be provided

Important Display parameters :

- Voltage
- Real time PF
- Current
- Power KW, KVA, KVAR
- Harmonics % ITHD, %VTHD

Features :

- Intelligent control
- Single CT sensing for balance loads.
- Large measurement and input voltage
- User friendly operation
- Power factor display up to 3rd decimal
- Protection against 6 basic parameters.

BR 4000ER

Technical Data:

- Steps - 4, 6 and 8 relay outputs
- Current Input - 1A or 5 A
- Supply Voltage - 110 VAC-550 VAC
- Measurement Voltage : 30...550 VAC (L-L/L-N)
- Operating temperature : 0 to 60 ° C
- Compact 96 x 96 x 75 mm
- Adapter plate for 144 x 144 cut out can be provided

Important Display parameters :

- Voltage
- Real time PF
- Current
- Power KW, KVA, KVAR
- Temperature
- Harmonics % ITHD, %VTHD, individual up to 31st
- Energy KWh, KVAh, KVARh

Features :

- Intelligent control
- Large measurement and input voltage range
- User friendly operation
- Individual harmonics up to 31st order
- Four quadrant operations
- RS 485 communication/real time clock (optional)
- 4 steps variant upgradable to 6 and 8 with additional module.
- Configurable alarm output for various parameters
- Recall recorded values for 10 various important parameters.

BR 5000



Technical Data :

- Steps - 8 and 16 relay outputs
- Current Input - 1A or 5 A
- Supply Voltage - 1Ph 415 VAC (-40% to +20%)
- Measurement Voltage : 3Ph 3 wire 415 VAC (-40% to +20%)
- Operating temperature : 0 to 70 ° C
- 144 x 144 mm front fascia
- Supply frequency 50 Hz

Important display parameters :

Same as per BR 4000ET

Features :

In addition to BR 4000ET

- Three CT sensing for unbalanced loads
- Dual target Power Factor setting - useful for utility and DG mode operation
- Automatic synchronization possible
- Separate 3 CT monitoring of healthiness of Capacitor within Panel
- Data logging
- RS 232 in front and RS 232/485 switchable connection at rear
- Step operation indication on LCD display plus LED which facilitates viewing from a distance
- Unique facility of including 'Fixed Capacitor Bank' for purpose of Transformer compensation. This can be set such that the controller doesn't 'see' this capacitor.
- Unique external temperature sensing by PT100
- Settable alarm facility - undervoltage, overvoltage and so on
- Settable auxiliary outputs - 2 Nos for Alarm, etc.
- Dynamic Power Factor Controller (Transistorised) available in 16 steps without PT100 facility available
- Special 8/16 step Controller for Medium Voltage application available
- EMI/EMC type tested.

BR 5100

New PF controller with various unique features such as:

- With GSM communication facility
- Programming from remote location
- Two way simplex communication via RS 232 or RS 485
- Sensitivity - up to 0.8% of sensed current
- PF value displayed to third decimal
- Smoke alarm sensing and messaging.

BR 6000



Technical Data :

- Steps - 6 and 12 outputs (in both relay and transistorised versions)
- Current Input - 1A or 5 A
- Supply Voltage - 1Ph - 230 V AC
- Measurement Voltage : 1Ph 30V - 525V AC (L-N) or (L-L)
- Operating temperature: -20 to +60° C
- Compact 144 x 144 mm front fascia

Important display parameters :

Same as per BR 4000ET

Features :

- Microcontroller logic for measurements
- Self explanatory menu navigation in several languages
- Self optimizing control capability
- Control modes : LIFO, FIFO and Self optimized Intelligent Control.
- Large and multifunctional LCD with backlit display (2 X 16 characters)
- Single CT sensing for balanced loads
- Dual target Power Factor setting (available in 12 stage) - useful for utility and DG mode operation available optional
- Automatic synchronization possible
- Display and storage of maximum values, number of switching operations and operating time
- Recall function of recorded values
- RS 232 Interface optional
- Alarm output optional
- Dynamic Power Factor Controller (Transistorised) available in 6 and 12 steps
- Cascading possible with master slave versions
- Protective earth terminal to reduce noise and unwanted interference signals
- EMI/ EMC type tested
- Individual Harmonic measurement upto 19th order.

* MRP of new products will be provided on request

Power Factor Controller

Rating KVAr	Steps	Voltage V	Description	Material Code	MRP/ Unit Rs.
Power Factor Controller					
BR4000	4	230	PFC CONTROLLER-BR-4904-04 ST RELAY 230V	B44066R4904A230N 1	12030
BR4000	8	230	PFC CONTROLLER-BR-4000-08 ST RELAY 230V	B44066R4808A230N 1	17160
BR5000	8	415	PFC CONTROLLER-BR-5000-08 ST-RELAY 415V	B44066R5908A415N 1	20210
BR5000	16	415	PFC CONTROLLER-BR-5000-16 ST-RELAY 415V	B44066R5916A415N 1	29190
BR5000	16	415	PFC CONTROLLER BR5000-16ST- TX 415V	B44066R5716A415N 1	40400
BR5000	8	415	PFC CONTROLLER BR5000-08ST- 415V HT	B44066R5308A415N 1	54440
BR5000	16	415	PFC CONTROLLER BR5000 - 16ST - 415 HT	B44066R5316A415N 1	65210
BR5000	5 x 3	240	PFC CONTROLLER BR5916S - 1 Ph x 3 - 5 steps per Phase	B44066R5916S240N 1	50630
BR5000	16	415	PFC CONTROLLER BR5100 - 16ST 3PH 415V with GSM	B44066R5916S415N 1	38780*
BR6000	6	230	BR6000 SERIES 6STP RELAY 230V	B44066R6006R230N 1	13730
BR6000	12	230	BR6000 SERIES 12 STP RELAY 230V	B44066R6012R230N 1	20580
BR6000	12	230	BR6000 SERIES T12 TRANSISTOR OUTPUT RELAY	B44066R6112R230N 1	29730
BR6000	6	230	BR6000 SERIES T6 TRANSISTOR OUTPUT RELAY	B44066R6106R230N 1	19440
BR6000	12	230	BR6000 SERIES (RS232 interface) 12 STP RELAY 230V	B44066R6312R230N 1	27440
BR6000	12	230	BR6000 SERIES (RS485 interface) 12 STP RELAY 230V	B44066R6412R230N 1	27440
BR7000	15	230	BR7000 SERIES 15 STEP RELAY 230V	B44066R7415E230	70010

* MRP is for basic model only . Cost of MODEM will be extra.

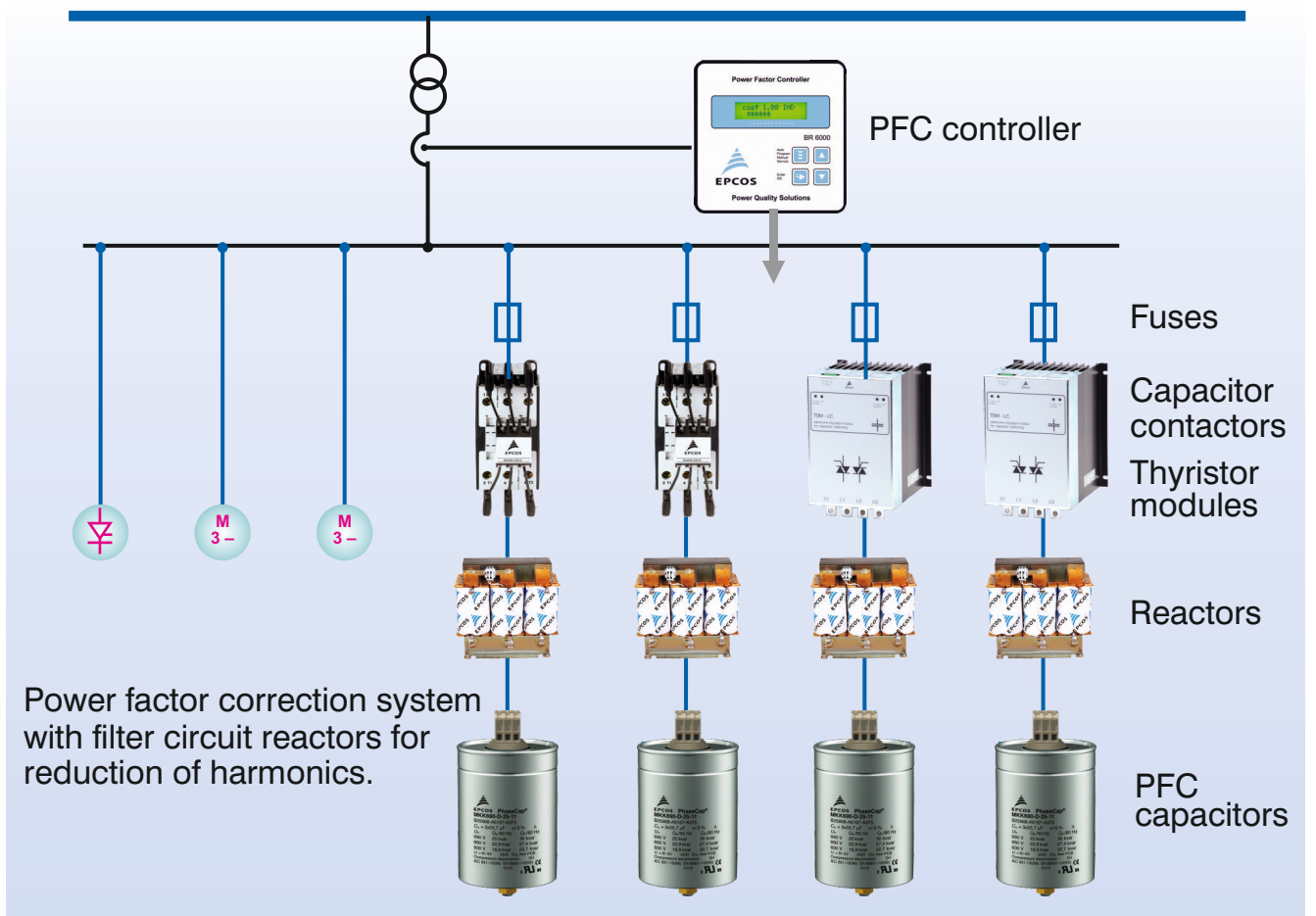

Capacitor Duty Contactors



Use of capacitor duty contactor enhance the life of the capacitors also limits the system transients thus improving power quality. Contactors have additional auxiliary contacts with current limiting resistors in series with it.

Specification :

- Technical data according to Standards IEC 947-4-1, IEC 947-5-1, EN 60947-4-1 EN 60947-5-1 and VDE 0660

Range :

- Rating: 7 KVAR to 100 KVAR
- Optional Voltage Range (380 V to 690 V)
- Operational ambient temperature up to 60° C

Features :

- Largest range
- Excellent damping of inrush current by the use of leading contacts with wiper function and special resistors
- Longer useful life of main contacts of capacitor Contactor
- Soft switching of contactor and thus longer useful life
- Weld resistant up to a possible peak inrush current of 200 times the rated capacitor current
- Enhance mean life expectancy of PFC systems
- Reduce Ohmic losses
- Tamper proof and protected resistors
- Suitable for use with or without detuned reactors
- Easy access for cable connection
- Type tested at CPRI
- AC-6b Utilisation category.

Thyristor Switch Module



Thyristor switching is used when load variation is rapid as in case of cranes, lifts, spot welding, plastic extrusion etc. As there are no moving parts the switching life is very high as compared to contactors. The power electronic devices used have a rated PIV of 2200, one of the highest in its class, thus enhancing the reliability of the module.

Range:

- Suitable for 10, 25 and 50 KVAR.
- Rated Voltage 400, 415, 440 and 690 V.

Features:

- Suitable for real time power factor correction.
- Easy Installation: It can be used identically as a Contactor.
- Reaction time: 5 milli seconds.
- Permanent self- controlling of :
 - Voltage Parameter
 - Capacitor Current
 - Temperature of the thyristor switch.
- Alarm output per module.
- Manual operation possible.
- Automatic switch off in case of over current and over temperature.
- Display of:
 - Operations
 - Faults
 - Activation.

Three Phase Filter Reactor



This is also known as anti-resonance three phase filter reactor. Detuned reactors are used with shunt capacitor banks to prevent harmonic resonance and also harmonic overloading of capacitor banks. These reactors are characterized by high linearity, low loss and compact size.

Range :

- Effective Filter out put 5 KVAR to 100 KVAR
- Filtering factor: - (5.67%, 7% and 14% corresponding to tuning frequencies of 210 Hz, 189 Hz and 134 Hz, for fundamental frequency of 50 Hz)
- Rated Voltage: (230 V to 690 V)
- Available in three designs
 1. Aluminum Strip Wound
 2. Aluminum Foil Wound
 3. Copper Conductor wound

Features :

- Highest linearity, low risk of reactor tilting
- Low losses and noise level
- High over loading capability
- Low weight in case of aluminum windings
- Safety device - temperature micro switch
- Type tested at CPRI.

Enclosed Capacitor Rack module

With the growth in power electronic devices the percentage of harmonics in the grid is increased. This has also grown the popularity of detuned harmonic filter within APFC panel. To utilize the existing APFC panels and to replace the plain capacitor with appropriate combination of Reactor - capacitor, EPCOS offers the specially designed Enclosed capacitor Rack module.

Technical Data :

- Standard Rating - 12.5, 25, 50 KVAR
- Voltage - 415V / 440V
- Capacitors - Phase Cap / Phi Cap
- Reactor - Aluminum / Copper wound

Features and Benefits :

- Appropriate selection of Capacitor and detuned harmonic filter reactor rating
- Easy installation and maintenance
- Standardized rating of components
- Can be used with existing panels and switchgear
- Natural Ventilation
- Best retrofitting option.

Capacitor Duty Contactors and TSM

Type	Rating KVAr	Voltage V (AC)	Description	Material Code	MRP/ Unit Rs.
Capacitor Duty Contactor - Standard Series					
Contactator - Standard series	7	240	7 KVAr Cap.DutyCont.1NO1NC240V	B44066S0711C240N 1	1980
Contactator - Standard series	10	240	10 KVAr Cap.DutyCont.1NO1NC240V	B44066S1011C240N 1	2220
Contactator - Standard series	12.5	240	12.5 KVAr Cap.DutyCont.1NO1NC240V	B44066S1211C240N 1	2400
Contactator - Standard series	16	240	16 KVAr Cap.DutyCont.1NO1NC240V	B44066S1611C240N 1	3170
Contactator - Standard series	20	240	20 KVAr Cap.DutyCont.1NO1NC240V	B44066S2011C240N 1	3620
Contactator - Standard series	25	240	25 KVAr Cap.DutyCont.1NO1NC240V	B44066S2511C240N 1	4040
Contactator - Standard series	33	240	33 KVAr Cap.DutyCont.1NO 2NC 240V	B44066S3312C240N 1	7890
Contactator - Standard series	40	240	40 KVAr Cap.DutyCont.1NO 2NC 240V	B44066S4012C240N 1	10980
Contactator - Standard series	60	240	60 KVAr Cap.DutyCont.1NO 2NC 240V	B44066S6012C240N 1	12210
Capacitor Duty Contactor - Premium Series					
Contactator - Premium series	12.5	230	Capacitor Contactor 50°C 0-12.5 KVAr	B44066S1811J230	4270
Contactator - Premium series	20	230	Capacitor Contactor 50°C 0-20 KVAr	B44066S2411J230	5350
Contactator - Premium series	25	230	Capacitor Contactor 50°C 0-25 KVAr	B44066S3211J230	5940
Contactator - Premium series	33.3	230	Capacitor Contactor 50°C 0-33.3 KVAr	B44066S5011J230	8900
Contactator - Premium series	50	230	Capacitor Contactor 50°C 0-50 KVAr	B44066S6211J230	9780
Contactator - Premium series	75	230	Capacitor Contactor 50°C 0-75 KVAr	B44066S7411J230	12590
Contactator - Premium series	100	230	Capacitor Contactor 50°C 0-100 KVAr	B44066S9911J230	23580
Thyristor Switch and Discharge Resistor					
TSM LC 10	10	440	Thyristor Switch Module 10 KVAr, 440V	B44066T10R440N 1	23960
TSM LC 25	25	440	Thyristor Switch Module 25 KVAr, 440V	B44066T25R440N 1	31160
TSM LC 50	50	440	Thyristor Switch Module 50 KVAr, 440V	B44066T50R440N 1	36870
TSM HV 50	50	690	Thyristor Switch Module 50 KVAr, 690V	B44066T50R690N 1	54440
EW22-Resistor	-	440	Discharge Resistor 22K, 50W, 5%	B44066T 22S400N 1	1170
EW22-Resistor, 690V	-	690	Discharge Resistor 22K, 50W, 5%, 690V	B44066T 22S690N 1	2310
Output Buffer Card, 24V	-	24	Buffer Card	B44066R1116R230N 1	8100

Important Information: 4

Power Factor Controllers:	Capacitor Duty Contactor:	Thyristor Modules (TSM)
<p>Controller hunting: When putting the capacitor bank into operation, it is required to avoid needless switching cycles (means permanent switching on and off of steps without significant change of consumer loads). This so called "controller hunting" would increase the number of switching operations of the connected contactors and capacitors, decrease the expected life cycle (wear out) and result, in worst case, in bursting and fire etc. This can be avoided by a proper programming of the PF controllers with the actual system parameters (current transformer prim. and sec., first KVAr step, control series, switching time).</p>	<p>Contactors are electromechanical switching elements used to switch Capacitors or Reactor and Capacitor in standard or de-tuned PFC system. Capacitor contactors with damping resistors make use of pre-switching auxiliary contacts. They close before the main contacts and pre-load the capacitor thus avoiding current peak values.</p> <p>This influences positively the life expectancy of the capacitor significantly, in addition to the positive impact on the power quality (avoiding transient and voltage sags that otherwise may be caused by switching in capacitors).</p>	<p>For discharging the capacitors, special high-voltage resistors type EW-22 are required. Standard resistors cannot be used!</p> <p>In dynamic PFC systems discharge reactors cannot be used (this would be a short circuit of the high voltage DC)!</p> <p>In PFC systems without filter circuit reactors current limiting reactors are required (e.g. BD-100) for the TSM.</p> <p>For short circuit protection, super fast electronic fuses for protection of the thyristor are required, standard HRC fuses are not suitable.</p> <p>Failure to follow cautions may result, worst case, in premature failures or physical injury.</p>

Detuned Filter Reactors

Type	Rating KVar	Voltage V (AC)	Description	Material Code	MRP/ Unit Rs.
Three Phase Detuned Filter Reactor (Aluminium Wound)					
HFR - AL - 7% DETUNED	5	440	H.FILTER REACTOR 5KVA _r , 7%	B44066D7005K440N 1	8230
HFR - AL - 7% DETUNED	10	440	H.FILTER REACTOR 10KVA _r , 7%	B44066D7010K440N 1	10590
HFR - AL - 7% DETUNED	12.5	440	H.FILTER REACTOR 12.5KVA _r , 7%	B44066D7012K440N 1	11720
HFR - AL - 7% DETUNED	15	440	H.FILTER REACTOR 15KVA _r , 7%	B44066D7015K440N 1	13200
HFR - AL - 7% DETUNED	20	440	H.FILTER REACTOR 20KVA _r , 7%	B44066D7020K440N 1	14060
HFR - AL - 7% DETUNED	25	440	H.FILTER REACTOR 25KVA _r , 7%	B44066D7025K440N 1	14660
HFR - AL - 7% DETUNED	30	440	H.FILTER REACTOR 30KVA _r , 7%	B44066D7030K440N 1	17610
HFR - AL - 7% DETUNED	40	440	H.FILTER REACTOR 40KVA _r , 7%	B44066D7040K440N 1	23420
HFR - AL - 7% DETUNED	50	440	H.FILTER REACTOR 50KVA _r , 7%	B44066D7050K440N 1	26360
HFR - AL - 7% DETUNED	60	440	H.FILTER REACTOR 60KVA _r , 7%	B44066D7060E440N 1	31650
HFR - AL - 7% DETUNED	75	440	H.FILTER REACTOR 75KVA _r , 7%	B44066D7075E440N 1	35120
HFR - AL - 7% DETUNED	80	440	H.FILTER REACTOR 80KVA _r , 7%	B44066D7080E440N 1	42160
HFR - AL - 7% DETUNED	100	440	H.FILTER REACTOR 100KVA _r , 7%	B44066D7100E440N 1	46820
HFR - AL - 14% DETUNED	10	440	H.FILTER REACTOR 10KVA _r , 14%	B44066D1410K440N 1	18740
HFR - AL - 14% DETUNED	25	440	H.FILTER REACTOR 25KVA _r , 14%	B44066D1425E440N 1	29290
HFR - AL - 14% DETUNED	50	440	H.FILTER REACTOR 50KVA _r , 14%	B44066D1450E440N 1	58540
HFR - AL - 5.67% DETUNED	10	440	H.FILTER REACTOR 10KVA _r , 5.67%	B44066D5010K440N 1	12710
HFR - AL - 5.67% DETUNED	25	440	H.FILTER REACTOR 25KVA _r , 5.67%	B44066D5025K440N 1	17610
HFR - AL - 5.67% DETUNED	50	440	H.FILTER REACTOR 50KVA _r , 5.67%	B44066D5050K440N 1	31650

Type	Rating KVar	Voltage V (AC)	Description	Material Code	MRP/ Unit Rs.
Three Phase Detuned Filter Reactor (Copper Wound)					
HFR - CU - 7% DETUNED	5	440	H.FILTER REACTOR 5KVA _r , 7%	B44066D7005J440N 1	10283
HFR - CU - 7% DETUNED	10	440	H.FILTER REACTOR 10KVA _r , 7%	B44066D7010J440N 1	13230
HFR - CU - 7% DETUNED	12.5	440	H.FILTER REACTOR 12.5KVA _r , 7%	B44066D7012J440N 1	14648
HFR - CU - 7% DETUNED	15	440	H.FILTER REACTOR 15KVA _r , 7%	B44066D7015J440N 1	16493
HFR - CU - 7% DETUNED	20	440	H.FILTER REACTOR 20KVA _r , 7%	B44066D7020J440N 1	17573
HFR - CU - 7% DETUNED	25	440	H.FILTER REACTOR 25KVA _r , 7%	B44066D7025J440N 1	18315
HFR - CU - 7% DETUNED	50	440	H.FILTER REACTOR 50KVA _r , 7%	B44066D7050J440N 1	32940
HFR - CU - 7% DETUNED	100	440	H.FILTER REACTOR 100KVA _r , 7%	B44066D7100J440N 1	58523
HFR - CU - 7% DETUNED	5	415	H.FILTER REACTOR 5KVA _r , 7%	B44066D7005J415N 1	10797
HFR - CU - 7% DETUNED	10	415	H.FILTER REACTOR 10KVA _r , 7%	B44066D7010J415N 1	13892
HFR - CU - 7% DETUNED	20	415	H.FILTER REACTOR 20KVA _r , 7%	B44066D7020J415N 1	18451
HFR - CU - 7% DETUNED	25	415	H.FILTER REACTOR 25KVA _r , 7%	B44066D7025J415N 1	19231
HFR - CU - 7% DETUNED	50	415	H.FILTER REACTOR 50KVA _r , 7%	B44066D7050J415N 1	34587
HFR - CU - 7% DETUNED	100	415	H.FILTER REACTOR 100KVA _r , 7%	B44066D7100J415N 1	61449

Important Information: 5

Detuned Filter Reactors

The power factor correction or capacitance of the power capacitor forms a resonant circuit in conjunction with the feeding transformer. Experience shows that the self-resonant frequency of this circuit is typically between 250 and 500 Hz, i.e. in the region of the 5th and 7th harmonics. Such a resonance can lead to the following undesirable effects:

- overloading of capacitors,

- overloading of transformers and transmission equipment,
- interference with metering and control systems, computers and electrical gear,
- resonance elevation, i.e. amplification of harmonics,
- voltage distortion.

These resonance phenomena can be avoided by connecting capacitors in series with filter reactors in the PFC

system. These so called "detuned" PFC systems are scaled in a way that the self-resonant frequency is below the lowest line harmonic. The detuned PFC system is purely inductive seen by harmonics above this frequency. For the base line frequency (50 or 60 Hz usually), the detuned system on the other hand acts purely capacitive, thus correcting the reactive power.

New

PhaseCap® Super Heavy Duty



A hi-tech capacitor with stud mounting cylindrical construction having high inrush current capability (Up to 500.IR) and Over current capability (up to 2.0 IR).

Specification :

- Conformance to standards IEC 60831- 1 & 2, EN60831-1 & 2

Range :

- 5 to 33 KVAR.
Voltage: 230V to 690V
(800/1000V on request)

Features :

- Manufactured using stat-of-art wavecut technology for MPP film with heavy edge
- Self healing property
- Low energy consumption
- Temp class: -40°C to 60°C
- Capable of withstanding high inrush current (**Up to 500.IR**)
- Very High life expectancy up to **2,00,000 operating hours (-40/D)**
- Capable for **15000 switching per year** to handle dynamic loads
- **Three phase safety device** in the form of pressure sensitive (over pressure) mechanical interrupter
- Compact size and light weight
- Soft biodegradable resin as impregnant.

New

PhaseCap® Energy Heavy Duty



A hi-tech capacitor with stud mounting Cylindrical construction with inert gas impregnated winding having very good inrush current capability and over current capability (up to 1.8 IR).

Specification :

- Conformance to Standards IEC 60831-1 & 2

Range :

- PhaseCap Energy Heavy Duty :
Single units from 5 to 33 KVAR
PhaseCap up to 56 KVAR
- Voltage : 230V to 690V
(800/1000V on request)

Features :

- Manufactured using state-of-art wave cut technology for MPP film with heavy edge
- Self healing property
- Low energy consumption
- Capable of withstanding high inrush current up to 400 IR
- Dry-type, freedom from oil leakage
- Three phase safety device in the form of pressure sensitive (over pressure) mechanical interrupter
- Compact size and light weight
- Temp class: -40/D

** MRP of above new products will be provided on request*



Capacitor (KVAR) selection chart

Current (ACTUAL) Tan φ	cos φ	achievable (TARGET) cos φ							TARGET Cos φ = 0.96		
		0.80	0.82	0.85	0.88	0.90	0.92	0.94	Cos φ ≤ 1		
		Factor F							0.96	0.98	1.00
3.18	0.30	2.43	2.48	2.56	2.64	2.70	2.75	2.82	2.89	2.98	3.18
2.96	0.32	2.21	2.26	2.34	2.42	2.48	2.53	2.60	2.67	2.76	2.96
2.77	0.34	2.02	2.07	2.15	2.23	2.28	2.34	2.41	2.48	2.56	2.77
2.59	0.36	1.84	1.89	1.97	2.05	2.10	2.17	2.23	2.30	2.39	2.59
2.43	0.38	1.68	1.73	1.81	1.89	1.95	2.01	2.07	2.14	2.23	2.43
2.29	0.40	1.54	1.59	1.67	1.75	1.81	1.87	1.93	2.00	2.09	2.29
2.16	0.42	1.41	1.46	1.54	1.62	1.68	1.73	1.80	1.87	1.96	2.16
2.04	0.44	1.29	1.34	1.42	1.50	1.56	1.61	1.68	1.75	1.84	2.04
1.93	0.46	1.18	1.23	1.31	1.39	1.45	1.50	1.57	1.64	1.73	1.93
1.83	0.48	1.08	1.13	1.21	1.29	1.34	1.40	1.47	1.54	1.62	1.83
1.73	0.50	0.98	1.03	1.11	1.19	1.25	1.31	1.37	1.45	1.63	1.73
1.64	0.52	0.89	0.94	1.02	1.10	1.16	1.22	1.28	1.35	1.44	1.64
1.56	0.54	0.81	0.86	0.94	1.02	1.07	1.13	1.20	1.27	1.36	1.56
1.48	0.56	0.73	0.78	0.86	0.94	1.00	1.05	1.12	1.19	1.28	1.48
1.40	0.58	0.65	0.70	0.78	0.86	0.92	0.98	1.04	1.11	1.20	1.40
1.33	0.60	0.58	0.63	0.71	0.79	0.85	0.91	0.97	1.04	1.13	1.33
1.30	0.61	0.55	0.60	0.68	0.76	0.81	0.87	0.94	1.01	1.10	1.30
1.27	0.62	0.52	0.57	0.65	0.73	0.78	0.84	0.91	0.99	1.06	1.27
1.23	0.63	0.48	0.53	0.61	0.69	0.75	0.81	0.87	0.94	1.03	1.23
1.20	0.64	0.45	0.50	0.58	0.66	0.72	0.77	0.84	0.91	1.00	1.20
1.17	0.65	0.42	0.47	0.55	0.63	0.68	0.74	0.81	0.88	0.97	1.17
1.14	0.66	0.39	0.44	0.52	0.60	0.65	0.71	0.78	0.85	0.94	1.14
1.11	0.67	0.36	0.41	0.49	0.57	0.63	0.68	0.75	0.82	0.90	1.11
1.08	0.68	0.33	0.38	0.46	0.54	0.59	0.65	0.72	0.79	0.88	1.08
1.05	0.69	0.30	0.35	0.43	0.51	0.56	0.62	0.69	0.76	0.85	1.05
1.02	0.70	0.27	0.32	0.40	0.48	0.54	0.59	0.66	0.73	0.82	1.02
0.99	0.71	0.24	0.29	0.37	0.45	0.51	0.57	0.63	0.70	0.79	0.99
0.96	0.72	0.21	0.26	0.34	0.42	0.48	0.54	0.60	0.67	0.76	0.96
0.94	0.73	0.19	0.24	0.32	0.40	0.45	0.51	0.58	0.65	0.73	0.94
0.91	0.74	0.16	0.21	0.29	0.37	0.42	0.48	0.55	0.62	0.71	0.91
0.88	0.75	0.13	0.18	0.26	0.34	0.40	0.46	0.52	0.59	0.68	0.88
0.86	0.76	0.11	0.16	0.24	0.32	0.37	0.43	0.50	0.57	0.65	0.86
0.83	0.77	0.08	0.13	0.21	0.29	0.34	0.40	0.47	0.54	0.63	0.83
0.80	0.78	0.05	0.10	0.18	0.26	0.32	0.38	0.44	0.51	0.60	0.80
0.78	0.79	0.03	0.08	0.16	0.24	0.29	0.35	0.42	0.49	0.57	0.78
0.75	0.80		0.05	0.13	0.21	0.27	0.32	0.39	0.46	0.55	0.75
0.72	0.81			0.10	0.18	0.24	0.30	0.36	0.43	0.52	0.72
0.70	0.82			0.08	0.16	0.21	0.27	0.34	0.41	0.49	0.70
0.67	0.83			0.05	0.13	0.19	0.25	0.31	0.38	0.47	0.67
0.65	0.84			0.03	0.11	0.16	0.22	0.29	0.36	0.44	0.65
0.62	0.85				0.08	0.14	0.19	0.26	0.33	0.42	0.62
0.59	0.86				0.05	0.11	0.17	0.23	0.30	0.39	0.59
0.57	0.87					0.08	0.14	0.21	0.28	0.36	0.57
0.54	0.88					0.06	0.11	0.18	0.25	0.34	0.54
0.51	0.89					0.03	0.09	0.15	0.22	0.31	0.51
0.48	0.90						0.06	0.12	0.19	0.26	0.48
0.46	0.91						0.03	0.10	0.17	0.25	0.46
0.43	0.92							0.07	0.14	0.22	0.43
0.40	0.93							0.04	0.11	0.19	0.40
0.36	0.94								0.07	0.16	0.36
00..33	95									0.13	0.33

$Q_c = PA \times (\tan \phi_1 - \tan \phi_2)$
 $Q_c \text{ (kvar)} = PA \times F = \text{active power (kW)} \times \text{factor "F"}$
 $PA = S \times \cos \phi = \text{apparent power} \times \cos \phi$
 $\tan \phi_1 + \phi_2$ according to $\cos \phi$ values ref. Table

Example:
 ACTUAL motor power $P = 100 \text{ kW}$
 Actual $\cos \phi = 0.61$
 TARGET $\cos \phi = 0.96$
 Factor F from table 1.01

Capacitor reactive power Q_c
 $Q_c = 100 \times 1.01 = 101.0 \text{ KVAR}$

Cautions

Mean life expectancy

The mean life expectancy of power capacitors is mainly governed by the following factors:

- Duration of overload,
- Ambient temperature and the resulting case temperature,
- Maximum rms current and the resulting case temperature,
- Voltage intensity (With respect to Capacitor rated voltage) and duration.

Fuse protection

Power capacitors have to be protected against short circuits by fuses or thermal magnetic over current relays. The fuse rating should be 1.6 to 1.8 times the rated current of the capacitor. Magnetic short circuit relays should be set between 9 to 12 times rated current to prevent them from nuisance tripping. Maximum allowed fault current of 10000 A in accordance with UL 810 standard must be ensured by the application design.

HRC fuses must not be used for switching. Resulting electric arcing can be very dangerous. It may also cause capacitor failures, and result, worst case, in capacitor bursting and fire.

Switching of capacitors

When a capacitor is switched to an AC system, the result is a resonant circuit damped to a greater or lesser degree. In addition to the rated current, the capacitor accepts a transient current that is a multiple of its rated current. Special capacitor contactors with leading contacts that feature precharging resistors to damp inrush currents are recommended. As per IEC 60831 standard, a maximum of 5000 switching operations per year is acceptable.

Discharging

Capacitors must be discharged to a maximum of 10% of rated voltage before they are switched in again. This prevents an electric impulse discharge in the application, influences the capacitor's useful life in PFC systems, and protects against electric

shock. The capacitor must be discharged to 50 V within 60 Sec. Caution: Discharge and short circuit capacitor before handling!

Capacitors in networks with harmonics

Most international standards limit THD-V on LV side to 5%. However it has to be noted that in many grids these levels are exceeded and even lower distortion, e.g. 3–4% THD-V can generate extreme over current in case of resonance condition. Maximum over current as specified under technical data of each series must not be exceeded.

Resonance must be avoided by appropriate panel design. Resonance may cause very high over current which can lead to capacitor failures, and worst case, to explosion and fire.

Connection:

Make sure connection cables are of flexible type or flexible copper bands are used. This is mandatory to allow the overpressure disconnecter work and avoid mechanical stress on the terminals and feedthroughs. Avoid bending cable lugs, cables or other mechanical force on the terminals. Otherwise leakages may set the safety device out of operation.

Grounding:

The threaded bottom stud of the cylindrical capacitor has to be used for grounding, where as in case of SquireCap capacitor the designated earthing screw should be used for this purpose.

Storage and operating conditions:

Do not use or store capacitors in corrosive atmosphere, especially where chloride gas, sulfide gas, acid, alkali, salt or the like are present. In dusty environments regular maintenance and cleaning especially of the terminals is required to avoid conductive path between phases and / or phases and ground.

Please visit our website www.epcos.com for more information on 'Applications, warnings, installation and maintenance instructions'



Extended Warranty Form (6 Months)

Type of Organisation : ▼

Organization :

Address

Country : ▼

State : ▼

City :

Contact Person :

Contact No :

Email-id :

Purchase Details

Name of Firm :

Contact Person :

Date : (e.g.) dd / MM / yyy

Details of Extended Warranty

Cap. Sr. No. :

ADD



SUBMIT

Note : Original bills are mandatory in case of claim against the extended warranty
Extended warranty period will be considered from the date of purchase of the product

QUICKLINKS

- Login
- Catalog
- Sales Network & Sites



Customer Care help line
number +91 1204505828
(Monday to Friday-9.00AM to
6.00PM)

Register your
PFC Capacitor on
<http://products.epcos.co.in/product>
in 1 min and get free extended warranty
for 6 month
Scheme valid till December 2017

Important information:

Some parts of this publication contain statements about the suitability to our products for certain areas of application. These statements are based on our knowledge of typical requirements that are often placed on our products. We expressly point out that these statements cannot be regarded as binding statements about the suitability of our products for a particular customer application. It is incumbent on the customer to check and decide whether the product is suitable for use in a particular application. This publication is only a brief product survey which may be changed from time to time. Our products are described in detail in our data sheets. The Important Notes (www.epcos.com/ImportantNotes) and the product-specific warnings and cautions must be observed. All relevant information is available through our sales offices.

Note:

1. This price list supercedes all previous price lists.
2. The prices are subject to change without notice.
3. Part numbers listed are for internal purpose and are subject to change.
4. Product improvement is a continuous process. For the latest information and special applications please contact any of our sales offices.

Authorized Dealer

For more details on products and applications please contact our nearest sales office or write to us at sales.in@epcos.com

Warranty:

1. Products manufactured by us are warranted against defects arising out of manufacturing processes or use of defective raw material, for a period of 18 months from the date of our supply or 12 months from the date of installation whichever is earlier. The company reserves the right to either replace or to repair the defective items after ascertaining facts through a detailed service report on appropriate usage of our products in rated conditions. The company reserves the right to take back the defective goods for carrying out study or inspection.
2. Warranty is not applicable if the products are found tampered with or subjected to calibration changes. The company's liability is limited to repair or replace the defective product only. The manufacturer shall not be liable for any consequential loss, injury or damages attributable to defect or failure of it's products.
3. Proof of purchase to be retained to avail warranty.
4. Any dispute arising in this regard shall be subjected to jurisdiction of courts in Nashik, in the state of Maharashtra - India.



EPCOS India Pvt. Ltd.

A TDK Group Company
Sales Head Office:
14/2, Rajesh Chambers, Brunton Road, Bengaluru 560001.
Tel: +91-80-4039 0640. Fax : +91-80-4039 0603.
Email: sales.in@epcos.com.

Regional Sales Offices:

Koikata Tel: +91-33-2419 8815.
Mumbai Tel: +91-22-2575 0800.
Noida Tel: +91-120-450 5801.
Bengaluru Tel: +91-80-4039 0640.

Fax: +91-33-2419 8815
Fax: +91-22-2575 0810
Fax: +91-120-450 5818
Fax: +91-80-4039 0603

"Product development is a continuous process. Consequently the data indicated in this price list is subject to change without prior notice. For the latest information, contact your local partners."